

# BEAM BRACKET TKO F 100/160

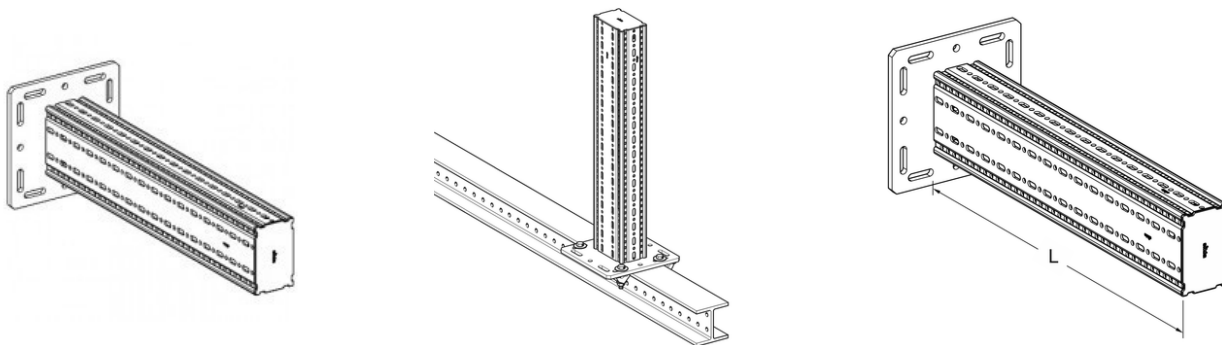

## APPLICATION

Galvanised hollow-box-section with welded end-plate to serve as cantilever arm. May be used as a crossbar when combined with End Support STA/End Support WBD and 4 x Self Forming Screw FLS.

## SCOPE OF DELIVERY

With pre-assembled End Cap ADK F100

## INSTALLATION

Depending on the situation, different options are recommended:

- a) Directly to building structure: 4x suitable wall anchors.
- b) To traditional steel beams between 100 - 180 mm flange dimensions: with Assmebly Set 5P M12 S.

### PROSYSTEM ITALIA SRL

Via Friuli venezia Giulia, 15  
30030 Pianiga - Venezia - Italy  
T +39.041.510.1622  
F +39.041.5131351

P.IVA 03470750278  
Reg.Imp. Ve 03470750278  
Cap.soc. € 90.000,00  
REA Padova n° 311219

[info@prosystemitalia.com](mailto:info@prosystemitalia.com)  
[prosystemitalia.com](http://prosystemitalia.com)

## TECHNICAL DATA

Type	L[mm]	Dimensions of base plate[mm]	Slots in base plate for
TKO F 100/160-800	800	280 x 280 x 12	M12
TKO F 100/160-1200	1200	280 x 280 x 12	M12

Configuration: Base plate welded to Beam Section TP F 100/160.

Material:

- Base plate: Steel, HCP;
- Beam Section: Steel, HCP.

## APPROVALS

CE mark, according to EN 1090.



Codice	Nome	Peso	Numero di pezzi
113097	TKO F 100/160 L= 800mm	18.56	1
113420	TKO F 100/160 L=1200mm	24.54	1
117145	AK F 160-100-E-1200	10.89	1
117146	AK F 160-100-E-1200	15.09	1

### PROSYSTEM ITALIA SRL

Via Friuli venezia Giulia, 15  
30030 Pianiga - Venezia - Italy  
T +39.041.510.1622  
F +39.041.5131351

P.IVA 03470750278  
Reg.Imp. Ve 03470750278  
Cap.soc. € 90.000,00  
REA Padova n° 311219

[info@prosystemitalia.com](mailto:info@prosystemitalia.com)  
[prosystemitalia.com](http://prosystemitalia.com)